

The most important technical data for thermostats

	Normal version	Ex-version
	 <p>... 200</p>	 <p>... 700</p>
Switch housing	Aluminium diecast GD Al Si 12	Aluminium diecast GD Al Si 12
Switching function and connection drawing (applies only for version with microswitch)	Floating change-over contact. With rising pressure switching over single-pole from 3-1 to 3-2	Floating change-over contact. With rising pressure switching over single-pole from 3-1 to 3-2
		
Switching capacity (applies only for version with microswitch)	10 A at 250 VAC 5 A at 250 VAC inductive 8 A at 24 V-	3 A at 250 VAC 2 A at 250 VAC inductive 0.1 A at 250 V- 0.01 A at 250 V-inductive
Installation position	arbitrary, preferably vertical	vertical
Degree of protection (in vertical position)	IP 54 (on request IP 65 by ZF 351)	IP 65
Ex degree of protection	-	EEx de IIC T6 tested to EN 50014/50018/50019 (CENELEC)
PTB approval	-	Ex-90.C. 1059
Electrical connection	Plug connection to DIN 43650	Terminal connection
Cable entry	Pg 11	Pg 11
Ambient temperature	-15 to +70 °C	-15 to +60 °C
Switching point	Adjustable on the spindle.	Adjustable on the spindle after the terminal box lid is removed.
Switching difference	Adjustable or not adjustable (see type overview)	Not adjustable
Medium temperature	Max. 70 °C, briefly 85 °C	Max. 60 °C
Vibration strength	Up to 4 g no noteworthy deviations. The switching difference is reduced slightly at higher accelerations. Use able 25 g not permissible.	
Insulations values (testing is currently in progress)	Overvoltage category III, contamination class 3, reference surge voltage 4000 V. The conformity to DIN VDE 01 10 (01.89) will be confirmed after completion of planned technical modifications to the switching mechanism.	

Temperature monitoring in explosion-endangered areas

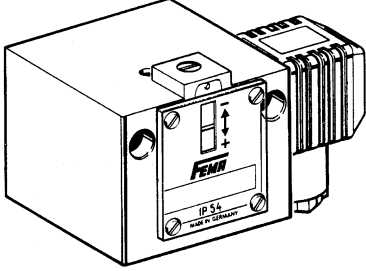
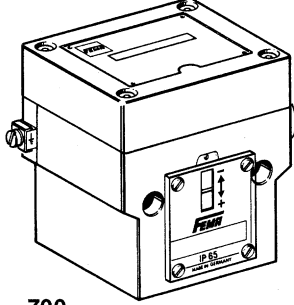
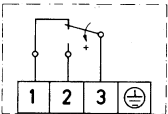
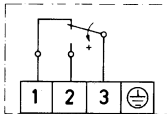

Temperature switches with special equipment can also be used in the Ex area \geq Zone 1.

The following alternatives are possible:

1. Thermostat with pressure-proof encapsulated switching device, degree of protection EEx de IIC T6

The thermostat in pressure-proof encapsulation can be used directly in the Ex area \geq Zone 1). Maximum switching voltage, switching capacity and ambient temperature must be taken into account and the rules for the installation in the Ex area must be observed.

All thermostats can be equipped with Ex switching mechanisms. Nevertheless, special circuits as well as versions with adjustable switching differences are not possible.

2. Thermostats in EExi version

All thermostats in normal version can be used in the Ex area \geq Zone 1 if they are incorporated in an "intrinsically safe circuit". In principle the intrinsic safety is based on that fact that the control circuit run in the Ex area carries only a small amount of energy which is not able to generate ignitable sparks.

Isolating switching amplifiers, e. g. Type EX 1 must be tested by the PTB and approved for Ex-installations.

Isolating switching amplifiers must in any event be installed outside the Ex zone.

Thermostats which are intended for EEx-ia installations can be equipped with blue terminals and cable entries. Because of the low voltages and currents which are carried by the contacts of the microswitch, gold plated contacts are recommended (additional function ZF 513).

3. Thermostats with inductive proximity switches in accordance with DIN 19234 (NAMUR)

Instead of the mechanical microswitch, contactless proximity switches can also be built into the thermostats. Combination of thermostats and proximity switches (ZF 512) and isolating switching amplifiers EX is permissible for Ex zone \geq 1, degree of protection EEx-ia. Here as well the isolation switching amplifier must be installed outside the Ex zone.

4. Pneumatic thermostats

No electrical energy is used in these thermostats and no ignition sparks can arise. A prerequisite is that instrument compressed air with a pressure of 1.4 bar is available and that the pneumatic output signal can be evaluated accordingly. Please refer to the data sheet PN for details (please request).

